

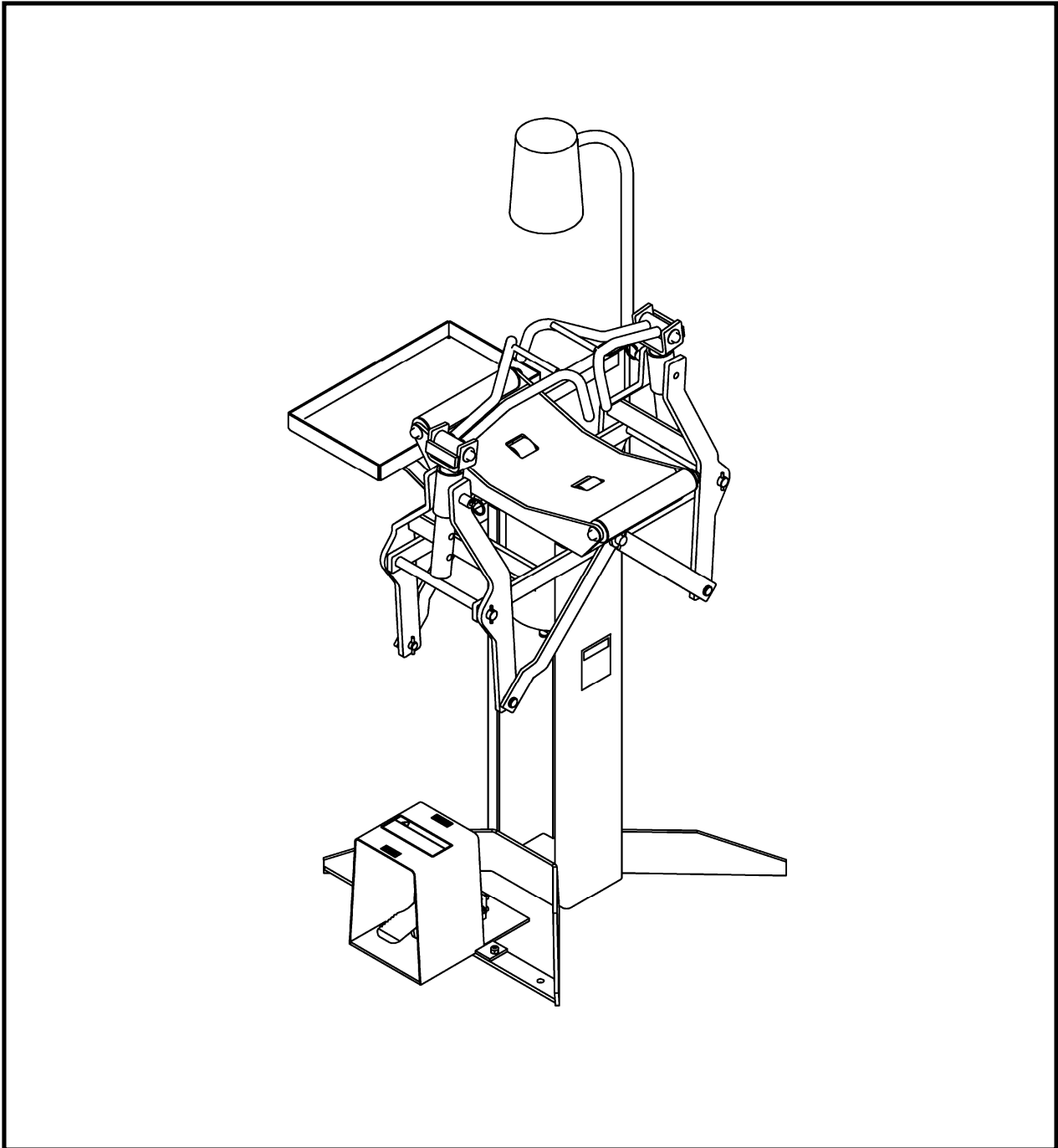

MODEL 5120
Tire Repair
Station

Installation, Operation
and Repair Parts
Information



CAUTION

- ◆ Before using this product, read and fully understand the operating instructions and all decals on the product. This is necessary to prevent injury to the operator and damage to the product.
- ◆ Use this product only for spreading and repairing tire casings. Do not use this product for any other purpose.
- ◆ Keep fingers and hands clear of spread hooks during tire spread.
- ◆ Do not use this product if it is visibly worn, distorted or damaged.
- ◆ Always wear appropriate eye protection.

INSTALLATION

- 1) Position the Model 5120 on a solid level floor. Bolting it to the floor is recommended.
- 2) Attach valve assembly to base of machine with fasteners provided.
- 2) Attach a 1/4 NPT quick coupler nipple (not provided) into the fitting located on the treadle valve assembly. Use 1/4 inch air hose with 100 p.s.i. minimum.

OPERATION

- 1) Position tire on rollers. Steady tire with hand and insert spread hooks between tire beads.
- 2) Adjust spread hooks to proper height for the tire size being repaired. The spread hook arms are held in position with a hitch pin. To adjust the spread hook arms, pull the hitch pin and move spread hook arm up or down to one of the four adjustment holes. Most larger truck tires will use the uppermost adjustment holes. Both spread hook arms must be adjusted to the same height.
- 3) Spread tire to desired width using the foot operated valve. If tire is lifted off tire rollers when it is spread, the spread hook arms are positioned too high and should be lowered.
- 4) To rotate tire to new position, release air pressure and rotate tire on rollers.
- 5) The attached work light can be adjusted to most favorable position.
- 6) After tire repairs are complete, actuate foot valve to release spread hook pressure and remove spread hooks from the tire bead.

MAINTENANCE

MONTHLY – Remove the airline from the fitting at the bottom of the spread cylinder and put a few drops of 10 or 20 weight oil in the airline. Reattach airline to fitting.

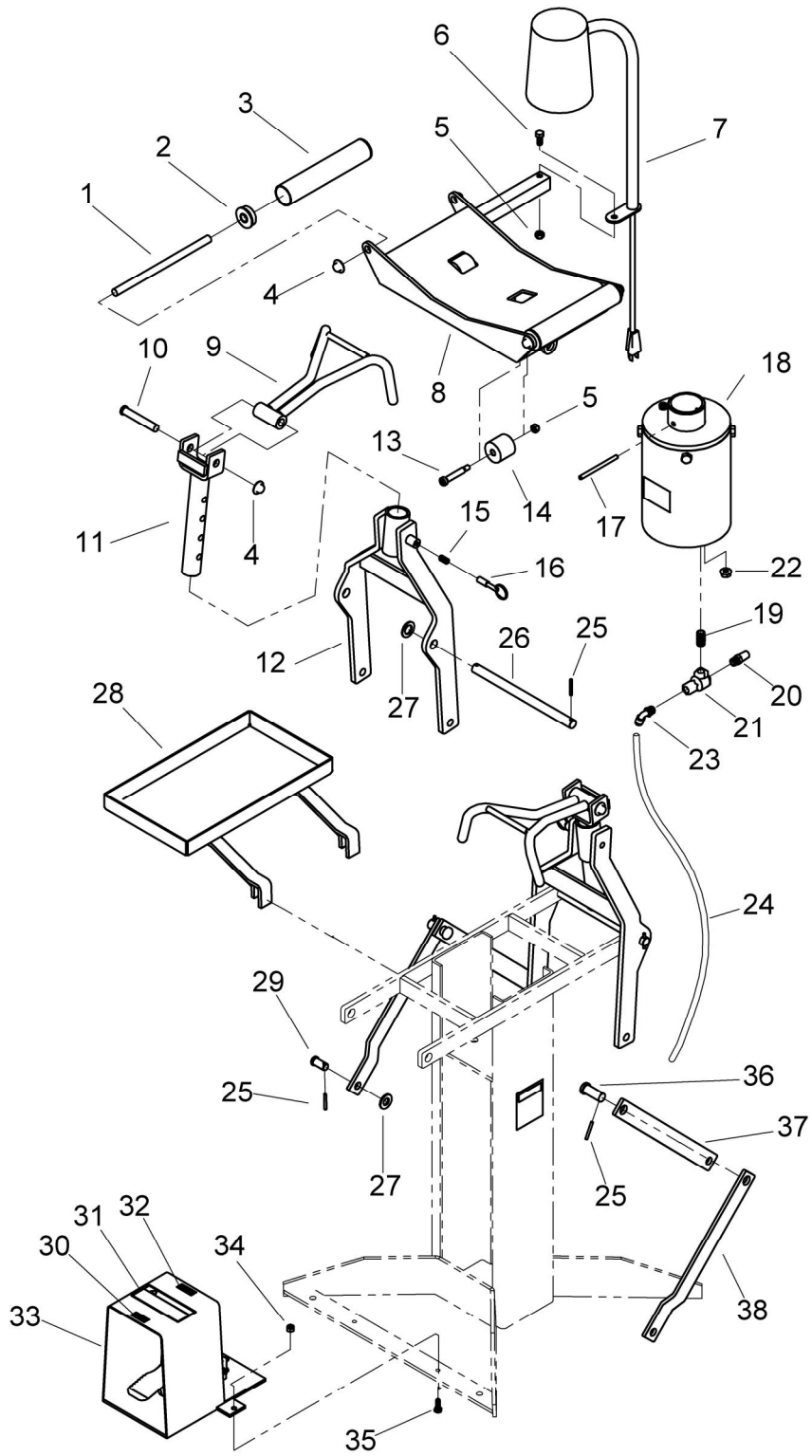

MAIN ASSEMBLY

MAIN ASSEMBLY

ITEM	PART NO	QTY	DESCRIPTION
1	149-316	2	Roller Rod
2	107-094	4	Bearing
3	268-542	2	Roller
4	020-024	6	Press On Cap
5	055-145	3	5/16-18 Nylon Hex Lock Nut
6	028-012	1	5/16-18 X 3/4 Hex Head Cap Screw
7	376-016	1	Lamp
8	03-0260	1	Tire Tray
9	03-0252	2	Spread Hook
10	54-0034	2	1/2 X 3 Clevis Pin
11	03-0261	2	Spread Hook Clevis
12	03-0258	2	Spread Arm
13	50-0072	2	3/8 X 1-3/4 Shoulder Screw
14	11-0046	2	Roller
15	110-065	2	Spring
16	73-0661	2	Stop Pin
17	061-111	1	1/4 X 3-1/2 Spring Pin
18	01-0189	1	Cylinder Assembly
19	096-221	1	1/4 NPT Close Nipple
20	885-035	1	Muffler
21	190-085	1	Quick Exhaust Valve
22	055-103	2	3/8-16 Serrated Flange Lock Nut
23	096-342	1	1/4 NPT X 1/4 Tube 90° Fitting
24	D20-007	20"	1/4 OD Airline
25	061-035	10	5/32 X 1-1/4 Spring Pin
26	73-0605	2	Pivot Rod
27	039-097	4	5/8 Machine Bushing
28	03-0299	1	Tool Tray
29	54-0003	4	1/2 X 1 Clevis Pin
30	026-067	1	Spread Decal
31	026-300	1	Caution Decal
32	026-066	1	Release Decal
33	01-0244	1	Valve Assembly
34	055-160	2	1/4-20 Nylon Hex Lock Nut
35	028-010	2	1/4-20 X 3/4 Hex Head Cap Screw
36	54-0038	2	5/8 X 1-1/2 Clevis Pin
37	73-0599	2	Inner Offset Link
38	73-0600	2	Outer Offset Link

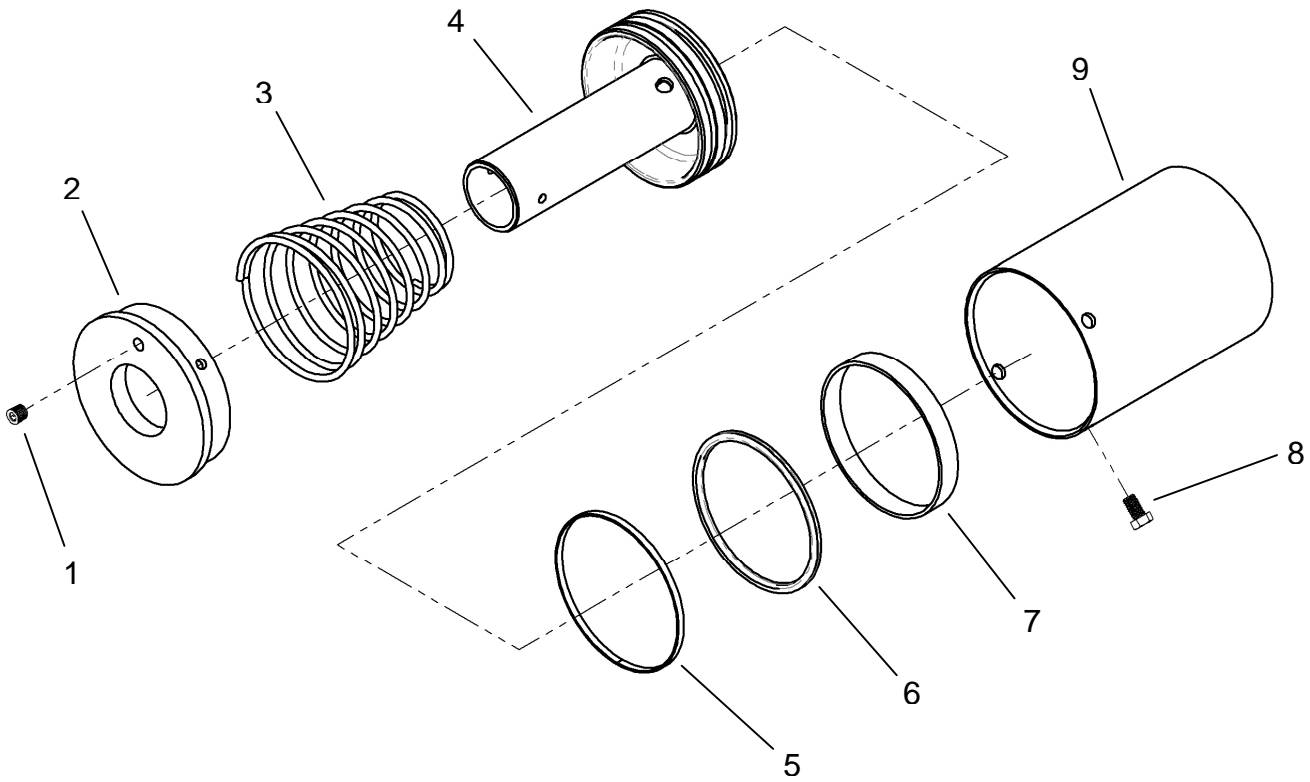

CYLINDER ASSEMBLY
SERIAL NO. 1826 AND LATER

ITEM	PART NO	QTY	DESCRIPTION
1	096-004	1	1/4" NPT Brass Hex Socket Head Plug
2	098-050	1	Cover Plate
3	110-001	1	Piston Spring
4	03-0262	1	Piston & Rod Assembly
5	D10-001	17.5"	Nylon Wear Strip
6	61-0038	1	5-5/8" Quad-Ring Seal
7	74-0306	1	Piston Spacer
8	028-005	4	7/16-14 X 3/4 Hex Head Cap Screw
9	03-0259	1	Cylinder Tube

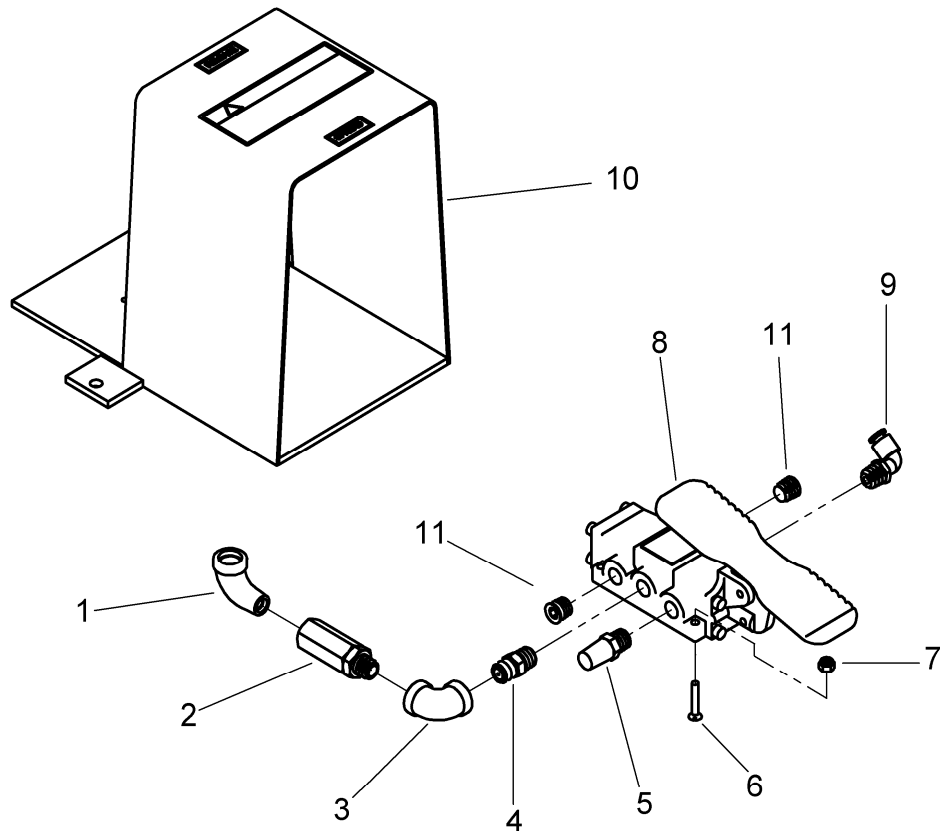

VALVE ASSEMBLY

ITEM	PART NO	QTY	DESCRIPTION
1	096-038	3	1/4 NPTF 90° Street Elbow Fitting
2	932-001	1	In-Line Filter
3	096-069	1	1/4-90° FEMALE NPT ELBOW
4	096-162	1	1/4 NPT Restricted Hex Nipple Fitting
5	885-035	1	Valve Muffler
6	50-0041	4	8-32 X 1 FLAT HD MACH SCREW
7	055-082	4	8-32 Nylon Hex Lock Nut
8	60-0009	1	Foot Valve
9	096-342	1	1/4 NPT X 1/4 Tube MALE ELBOW
10	03-0431	1	Foot Valve Guard
11	096-004	2	1/4 NPT HSH PLUG

Branick Industries, Inc.

COMMERCIAL WARRANTY

This product is warranted by BRANICK INDUSTRIES, INC. to the original user-owner against defective materials or workmanship. During the warranty period, if Branick determines the product to be defective, it will be repaired or replaced (at Branick's option) without charge.

Warranty Period 1 year from date of delivery.

This warranty does not cover defects in the product caused by ordinary wear and tear, abuse, misuse, overloading, accident (including shipping damage), improper maintenance, alteration, or any other cause not the result of defective materials or workmanship.

REPLACEMENT IS THE EXCLUSIVE REMEDY FOR DEFECTIVE PRODUCT UNDER THIS WARRANTY. THIS WARRANTY IS EXPRESSLY IN LIEU OF ALL OTHER WARRANTIES, INCLUDING ANY IMPLIED WARRANTY OF MERCHANTABILITY OR ANY IMPLIED WARRANTY OF FITNESS FOR A PARTICULAR PURPOSE OF THIS PRODUCT. BRANICK INDUSTRIES, INC. SHALL NOT BE LIABLE FOR ANY CONSEQUENTIAL OR INCIDENTAL DAMAGES.

BRANICK INDUSTRIES, INC. reserves the right to make changes in the design or construction of our products without obligation to incorporate such changes in products already sold and without notice.

Service parts, warranty, and regular repair service are available from:

**BRANICK INDUSTRIES, INC.
4245 Main Ave.
Box 1937
Fargo, North Dakota 58107
701/281-8888**

Branick®
INDUSTRIES, Inc.